

Impact of Active Cooling Systems on Solar Panel Efficiency and Net Energy Production

Ferry R A Bukit

Department of Electrical Engineering
Universitas Sumatera Utara
Medan, Indonesia
ferrybukit@usu.ac.id

Yanuar Z. Arief

Dept. of Electrical and Electronic Eng.,
Faculty of Engineering
Universiti Malaysia Sarawak (UNIMAS)
Sarawak, Malaysia
ayzulardiansyah@unimas.my

Arman Sani

Department of Electrical Engineering
Universitas Sumatera Utara
Medan, Indonesia
armansani.usu@gmail.com

Riswan Dinzi

Department of Electrical Engineering
Universitas Sumatera Utara
Medan, Indonesia
dinziriswan@gmail.com

Pribadi Prima Sitompul

Department of Electrical Engineering
Universitas Sumatera Utara
Medan, Indonesia
pribadi.ps@gmail.com

Abstract— The operation of solar panels is highly dependent on environmental conditions to provide a reliable power source. Temperature is one of the important ecological factors that directly affect the performance of solar panels, as higher operating temperatures reduce efficiency. In this study, two active cooling systems were applied to solar panels: water and air cooling using a heatsink and fan. The aim was to analyze the efficiency by comparing the energy produced by the panels with the energy consumed by the cooling systems. The results showed that solar panels equipped with a cooling system improved the operating efficiency compared to those without cooling. Among the tested methods, solar panels equipped with a heatsink and fan demonstrated the highest average operational efficiency, reaching 17.912%, followed by the water-cooling system, which achieved 17.832%. In contrast, solar panels without a cooling system showed the lowest average efficiency of 17.161%, highlighting the important role of thermal management in panel performance. However, when considering net energy output, the water-cooling system produced the highest net energy production, which was approximately 518.501 Wh, representing a 2.887% increase compared to the uncooled panel (503.951 Wh). In contrast, although the heatsink system improved instantaneous efficiency, its higher energy consumption resulted in a net energy output of only 455.900 Wh, which is 9.535% lower than that of the uncooled panel. These findings suggest that while active cooling improves solar panel performance, the choice of cooling method must consider both efficiency and energy consumption improvements to maximize net energy production.

Keywords—Energy, solar, cooling system, efficiency, thermal

I. INTRODUCTION

Until now, the supply of electrical energy has been very dependent on non-renewable energy sources like oil and coal, which can damage the environment. By utilizing solar panel technology, which converts solar energy into electrical energy, we can meet our increasing demand for electrical energy. Also, solar energy is believed to be a breakthrough in the world's future energy [1]. Temperature is a factor that is exceptionally influential on the output power of solar panels. When solar panels operate outside the ideal temperature, their output power decreases[2], [3]. Therefore, we need a cooling system that supports its operation to keep it in perfect condition[4].

From an operational point of view, solar panel cooling systems can be grouped into two types: active and passive cooling systems [5], [6]. An active cooling system is a system that requires electrical power to operate. The advantage of an active cooling system is that it achieves higher efficiency

compared to a passive cooling system. The passive cooling system is a system that does not require electrical power to operate[7]. The advantage of a passive cooling system is that it saves money and electricity in its operation[8], [9].

The efficiency of photovoltaic (PV) panels is significantly influenced by the type of cell, radiation intensity, and cell temperature, with temperature rise being a significant factor in efficiency reduction, especially in tropical regions [10]. Various studies have shown that both active and passive cooling systems can enhance PV panel performance, each with its advantages and drawbacks. A survey in Jiroft, Iran, demonstrated that using an active fan cooling system increased the panel's power output by up to 12%, resulting in a net efficiency improvement of about 7% after accounting for the fan's power consumption. Another study compared two water-cooling methods: PV-FW, which uses a transparent water channel in front of the panel, and PV-BW, which employs a cooling plate at the back. These methods reduced surface temperatures by 22.4°C and 17.8°C, respectively, with PV-BW showing a 6.86% increase in electrical efficiency, while PV-FW, although less effective electrically due to light transmission losses, proved better for thermal energy collection applications. In general, passive cooling methods are cost-effective and easier to implement but offer limited efficiency gains[11], [12].

In contrast, active cooling systems deliver higher efficiency improvements but are more expensive and complex to install. Fluid-based active cooling techniques, such as jet impingement and spectrum filtering, have shown remarkable efficiency enhancements of over 50%. Yet, future research is recommended to focus on simpler, low-maintenance cooling technologies that are easier to install and more practical for both residential and large-scale applications [11].

In this study, the author designed a solar panel cooling system using two methods. The first method is a water cooling system, which features a nozzle on the front side of the solar panel and a sprinkler on the back side. The second method is a heatsink with a fan. Given that the ideal temperature for solar panels is 25°C and that temperature increases can reduce power output, this study compares which cooling method can maintain the solar panel temperature closer to the ideal temperature [13], [14]. This study not only examines the power output of the solar panel but also reviews energy consumption by comparing the energy generated by the solar panel with the energy required by its cooling system. With the cooling system being researched, it is hoped that the

performance of the solar panel can be improved with more efficient energy consumption.

II. METHOD

A. Design Planning

To conduct this research, the equipment and materials used include a 120 Wp Monocrystalline Solar Panel as the primary energy source, an Arduino Mega 2560 microcontroller for system control and data acquisition, along with voltage and current sensors (ACS 712) to measure electrical output parameters. A DS18B20 temperature sensor is utilized to monitor the panel's surface temperature, while a 2-channel relay module controls the activation of cooling components. Additional measuring tools, such as a multimeter and a thermometer gun, are employed for validation and manual monitoring. The cooling system consists of a 24V DC water pump, a 24V DC fan, and an aluminum heatsink, all powered by a 24V DC power supply, to manage the thermal regulation of the solar panel during operation.

In conducting this research, the authors have prepared a detailed sketch of the research design to illustrate the overall experimental setup and arrangement of components involved in the study. This sketch serves as a visual representation of how the solar panel, sensors, cooling systems, and other supporting equipment are positioned and interconnected within the research framework. The front view of the design, as depicted in Fig. 1, clearly shows the placement of key elements such as the monocrystalline solar panel, temperature and current sensors, water cooling nozzles, fan, aluminum heatsink, and control devices like the Arduino microcontroller and relay modules. This visual aid is essential to provide a comprehensive understanding of the research methodology and to ensure clarity in explaining the operational workflow of the cooling systems being tested.

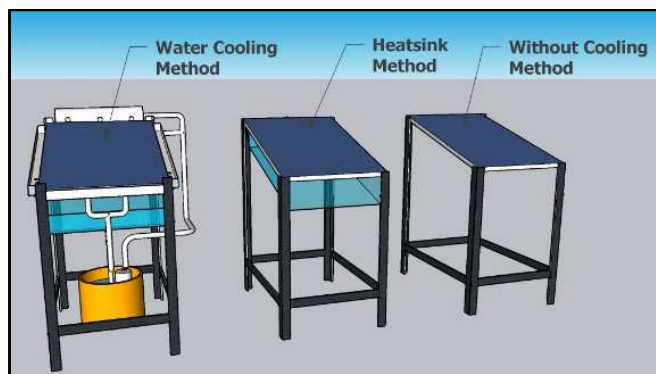

Fig. 1. The front view of the design

Fig. 2 illustrates the circuit design developed with the primary objective of recording essential parameters to evaluate the performance of the solar panels under various operating conditions. The key parameters measured in this study include the open circuit voltage (V_{oc}), short circuit current (I_{sc}), and the surface temperature of the solar panel, which are critical indicators of its electrical efficiency and thermal behavior [15]. Additionally, solar radiation intensity is also monitored to correlate environmental factors with panel performance. All these data are collected in real-time through a network of sensors connected to an Arduino Mega microcontroller, which functions as the central data acquisition unit. The Arduino processes and transmits the recorded data to a laptop, where the information is

systematically logged and displayed using Microsoft Excel for further analysis and visualization. This data flow ensures accurate monitoring and facilitates comprehensive assessment of the solar panel's output performance throughout the experiment.

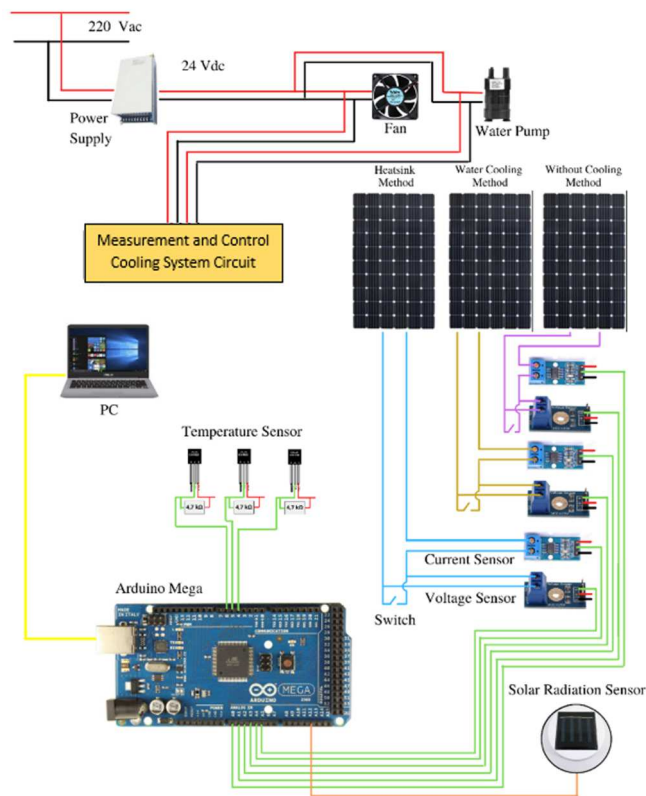

Fig. 2. Solar panel measurement and control circuit

The recorded data for the cooling system is the voltage and current of the load while working and controlling the cooling system using a relay to be able to regulate the load, so that it starts active working when it reaches the temperature of 45 °C and shuts off at 40 °C [16], [17]. The data read by the sensor will be received by the Arduino Mega and forwarded to a laptop, where it can be read in Microsoft Excel.

B. Research Procedure

To ensure that the research is conducted systematically, a series of procedural stages has been established as part of the research methodology. Initially, each solar panel is positioned on a specially designed frame, as shown in Figure 1. The first cooling method involves a water cooling system where nozzles spray water on the front side of the panel while a sprinkler cools the back side. The second method utilizes a heatsink and fan mounted on the back of the panel to dissipate heat. Both the water pump and fan are programmed to activate when the panel's temperature reaches 45°C and deactivate once it drops to 40°C, with power supplied from external solar panels [16]. During operation, the voltage and current of the active loads (water pump and fan) are recorded to determine their power consumption. Various sensors are installed to continuously monitor changes in voltage, current, temperature, and solar radiation, with data collected via an Arduino microcontroller and displayed on a PC for real-time monitoring. The testing phase is conducted over three consecutive days from 08.00 to 17.00 WIB, with data being logged into Microsoft Excel at hourly intervals. The collected data is then analyzed to compare the performance of the solar

panels under different cooling conditions. The detailed research procedure flowchart is presented in Fig. 3.

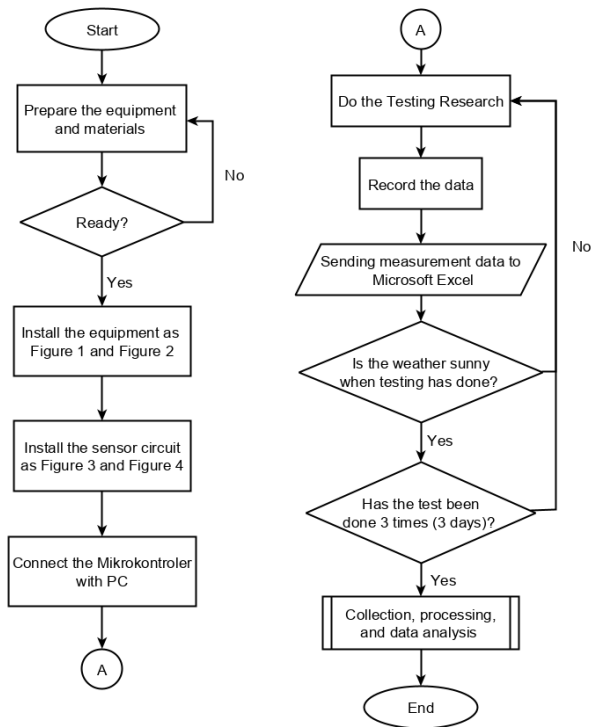

Fig. 3. Research Procedure Flowchart

III. RESEARCH RESULTS AND DISCUSSION

After the research procedure has been carried out correctly, data variables measured from the solar panel will be obtained, allowing the author to perform calculations to determine the energy produced by the solar panel and the energy required by the cooling system during operation. The application of a water-cooling system can be seen in Fig. 4,

and an active cooling system using a heatsink and fan can be seen in Fig.5.



Fig. 4. Application of water cooling systems

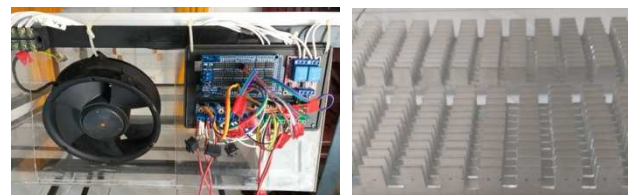

Fig. 5. Application of heatsink with air drawn using a fan systems

Table 1 presents the results of measuring the performance parameters of solar panels under three different cooling conditions: without a cooling system, with a watercooling system, and with an active heatsink cooling system, over a full day from 08:00 to 17:00 WIB. The parameters recorded include solar radiation intensity (W/m^2), panel surface temperature (T), open-circuit voltage (V_{oc}), short-circuit current (I_{sc}), fill factor (FF), input power (P_{in}), and output power (P_{out}).

TABLE I. MEASUREMENT AND CALCULATION RESULTS

Time	Intencity (W/m^2)	Without Cooling System						Water Cooling System						Active Heatsink Cooling System					
		T ($^{\circ}C$)	Voc (V)	Isc (A)	FF	Pin (W)	Pout (W)	T ($^{\circ}C$)	Voc (V)	Isc (A)	FF	Pin (W)	Pout (W)	T ($^{\circ}C$)	Voc (V)	Isc (A)	FF	Pin (W)	Pout (W)
08.00	317.21	29.628	20.793	2.184	0.813	216.782	36.933	29.657	20.829	2.184	0.814	216.782	37.012	29.653	20.809	2.184	0.813	216.782	36.964
09.00	342.50	33.553	20.835	2.354	0.814	234.063	39.902	33.551	20.853	2.354	0.814	234.063	39.951	33.598	20.851	2.353	0.814	234.063	39.935
10.00	373.00	37.174	20.884	2.568	0.814	254.906	43.664	37.140	20.903	2.569	0.814	254.906	43.719	37.077	20.901	2.568	0.814	254.906	43.700
11.00	390.68	41.924	20.747	2.695	0.813	266.993	45.536	41.972	20.793	2.695	0.813	266.993	45.669	41.917	20.789	2.695	0.813	266.993	45.644
12.00	418.70	44.620	21.185	2.883	0.816	286.141	49.841	43.368	21.204	3.011	0.816	286.141	52.099	43.516	21.202	3.028	0.816	286.141	52.390
13.00	510.87	46.243	21.227	3.518	0.816	349.128	60.953	43.133	21.246	3.814	0.816	349.128	66.148	43.249	21.244	3.860	0.816	349.128	66.951
14.00	515.45	45.983	21.202	3.554	0.816	352.260	61.495	42.408	21.221	3.935	0.816	352.260	68.166	42.487	21.219	3.989	0.816	352.260	69.091
15.00	502.92	45.442	20.939	3.463	0.814	343.696	59.059	42.661	20.958	3.746	0.814	343.696	63.955	42.979	20.956	3.760	0.814	343.696	64.184
16.00	485.00	45.145	20.754	3.340	0.813	331.447	56.369	42.669	20.773	3.525	0.813	331.447	59.563	42.648	20.771	3.563	0.813	331.447	60.199
17.00	436.88	38.593	20.565	3.006	0.812	298.563	50.198	38.652	20.583	3.007	0.812	298.563	50.261	38.659	20.581	3.006	0.812	298.563	50.240

From the data, it is evident that both the water-cooling system and the active heatsink cooling system effectively reduce the surface temperature of the solar panels compared to panels without any cooling system, particularly during peak sunlight hours. For instance, at 13:00 WIB with a solar radiation intensity of $510.87 W/m^2$, the panel temperature

without cooling reached $46.243^{\circ}C$. In contrast, the water-cooling system and active heatsink cooling system lowered the temperature to $43.133^{\circ}C$ and $43.249^{\circ}C$, respectively. This temperature reduction directly influenced the output power (P_{out}), where the panel without cooling generated $60.953 W$. In comparison, the water-cooling system increased the output

to 66.148 W. The active heatsink further boosted it to 66.951 W. These results indicate that temperature control significantly contributes to improving panel performance, with the active heatsink showing a slight advantage in maintaining stable temperatures and enhancing power output.

Overall, the data trends indicate that both the water-cooling system and the active heatsink cooling system positively affect panel performance throughout the day, with their effectiveness becoming more pronounced during periods of moderate to high solar radiation. In the early morning hours (08:00-10:00 WIB), the differences in output power among the three methods are relatively small as panel temperatures have not yet reached critical levels. However, as solar intensity increases during midday (12:00-14:00 WIB), the cooling systems significantly enhance the panel's output power by approximately 15-20% compared to panels without cooling. Interestingly, the active heatsink consistently delivers slightly higher output power than the water-cooling system, although the margin is relatively small. This suggests that the active heatsink is more effective in maintaining panel performance stability with minimal additional energy consumption, making it a more practical solution for long-term applications in tropical regions with high ambient temperatures.

The temperature comparison graph clearly shows that both the water-cooling system and the active heatsink cooling system effectively reduce the surface temperature of the solar panels compared to panels without cooling, especially during peak sunlight hours show at Fig. 6. Without cooling, panel temperatures rise significantly, reaching up to 46°C, which negatively impacts performance. The water-cooling system reduces the panel temperature by approximately 2°C–3°C, while the heatsink cooling system maintains even better stability with slightly lower temperatures throughout the day. The difference is minimal in the morning when solar intensity is low, but it becomes crucial during midday when heat accumulation is highest. These results highlight the importance of implementing effective cooling strategies to control temperature rise, thereby maintaining the panel's efficiency and protecting its operational lifespan, particularly in tropical regions with high ambient temperatures.

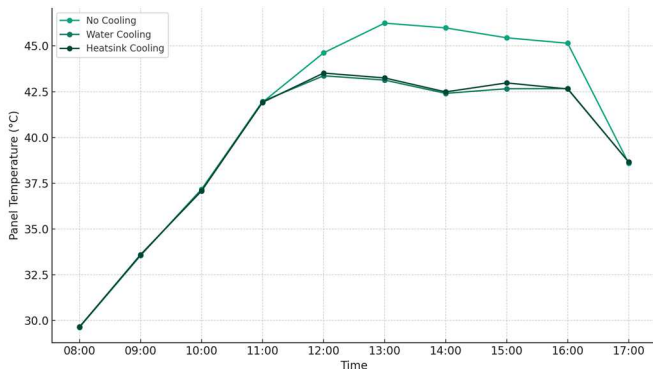

Fig. 6. The Temperature Comparison

The efficiency comparison graph in Figure 6 shows that both the water cooling system and the active heatsink cooling system significantly enhance the efficiency of solar panels compared to panels without cooling, especially during peak sunlight hours when temperature rise becomes critical. While the difference is minimal in the morning, the effect of cooling becomes more evident from midday onwards, with the active

heatsink consistently maintaining the highest efficiency throughout the day, slightly outperforming the water cooling method. This indicates that effective temperature control is essential in sustaining panel performance under high solar radiation, particularly in tropical climates. The active heatsink cooling system proves to be the most reliable solution in mitigating temperature-induced efficiency losses, ensuring the solar panel operates closer to its optimal performance range and thus maximising energy output over the day.

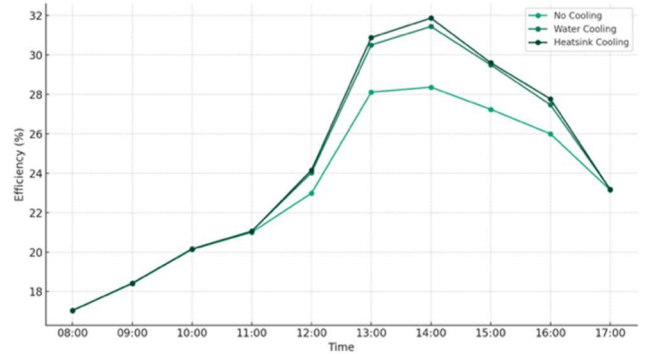

Fig. 7. Solar Panel Efficiency Comparison

Based on the data analysis, the efficiencies of the three types of solar panels were relatively similar in the morning (± 11.6 – 11.7%) when panel temperatures were still low. However, differences became noticeable towards midday, particularly between 12:00 and 14:00 when solar radiation intensity and temperatures peaked. During this period, the panel without cooling reached an efficiency of around 11.9%, while the water cooling system increased it to approximately 12.95–13.22%, and the heatsink cooling system performed slightly better at around 13.10–13.40%, representing an improvement of about 1.2–1.5 percentage points over the non-cooled panel.

A. Energy Calculation

The total electrical energy generated by a solar panel over a specific period is calculated using Equation (1). In this formula, P_{out} represents the instantaneous output power of the solar panel, measured in watts, while t denotes the duration of operation at that power level, measured in hours. By multiplying these two variables, the total energy output of the solar panel can be determined in watt-hours (Wh). This calculation is essential for quantifying the gross energy production of the solar panel system before accounting for any auxiliary power consumption, such as energy utilized by cooling systems.

$$E_{PV} = P_{out} \times t \quad (1)$$

The energy consumption of the cooling system load, which includes components such as fans or water pumps that regulate the solar panel's operating temperature within optimal limits, is determined using Equation (2). In this equation, P denotes the power consumption rating of the cooling device (in watts), and t represents the duration of its operation (in hours). Multiplying these values yields the total energy consumed by the cooling system, expressed in watt-hours (Wh). This calculation is crucial for assessing how much of the energy produced by the solar panel is allocated to maintaining temperature regulation, thus influencing the net usable energy available for other applications.

$$E = P \times t \quad (2)$$

$$\sum E_{Clean} = E_{Solar\ Panel} - E_{Cooling\ System} \quad (3)$$

Equation (3) is employed to calculate the net, or “clean,” energy output of the solar panel by subtracting the energy consumed by the cooling system from the total energy generated. This equation provides a more precise evaluation of the solar panel system's effective energy contribution after internal energy losses are considered. The resulting clean energy value reflects the actual usable electrical energy that can be harnessed for end-use applications, offering a more realistic depiction of the system's overall efficiency and energy sustainability. This assessment is particularly important when active cooling techniques are implemented to mitigate the adverse effects of thermal performance degradation on solar panels.

TABLE II. THE COMPARISON OF CLEAN ENERGY OUTPUT

Clean Energy Each Solar Panel Method (Watt-Hour)			
Method	Solar Panel Energy	Cooling System Energy	Clean Energy
Without Cooling	503.95	0.00	503.95
Water Cooling	526.54	8.04	518.50
Heatsink Cooling	529.29	73.39	455.90

The Table 2. presents the comparison of clean energy output for three different solar panel configurations: without cooling, with water cooling, and with heatsink active cooling. The "Solar Panel Energy" column represents the total gross energy produced by the solar panels during the testing period, while the "Cooling System Energy" column indicates the amount of electrical energy consumed by the respective cooling systems. The "Clean Energy" column is the net energy obtained by subtracting the cooling system's energy consumption from the total solar panel energy, reflecting the actual usable energy.

For the solar panel without any cooling system, the total energy produced was 503.951 Wh. Since no additional energy was consumed for cooling, the clean energy remains the same at 503.951 Wh. In the water cooling method, the solar panel generated a slightly higher total energy of 526.544 Wh, with the cooling system consuming 8.043 Wh. After accounting for this consumption, the resulting clean energy output is 518.501 Wh, which shows an increase compared to the panel without cooling.

In the case of the heatsink active cooling method, the solar panel achieved the highest gross energy production of 529.298 Wh. However, this method also consumed a significantly larger amount of energy for its operation, namely 73.398 Wh. After subtracting the energy used by the cooling system, the clean energy output was reduced to 455.900 Wh, which is lower than the clean energy produced by both the water cooling method and the panel without cooling.

This data illustrates that while active heatsink cooling enhances gross energy production due to better thermal management, its high energy consumption reduces the net (clean) energy output, making it less efficient in terms of overall energy gains compared to the water cooling method. The water cooling system, on the other hand, offers a balance between improved energy production and minimal energy

consumption, resulting in the highest clean energy yield among the three methods.

IV. CONCLUSIONS

The implementation of a cooling system has proven effective in reducing the surface temperature of solar panels, thereby enhancing their overall performance. Among the tested methods, the solar panel equipped with an active heatsink cooling system exhibited the highest average operational efficiency, achieving a value of 17.912%. This is followed closely by the water cooling system, which achieved an average efficiency of 17.832%. In contrast, the solar panel operating without any cooling system demonstrated the lowest average efficiency at 17.161%, indicating the significant impact of thermal management on panel performance.

In terms of net (clean) electrical energy output, the solar panel utilising the water cooling system produced the highest energy yield, amounting to 518.501 Watt-Hours, which represents an increase of 2.887% compared to the panel without cooling, which generated 503.951 Watt-Hours. Conversely, although the heatsink cooling system improved the panel's instantaneous efficiency, its relatively high energy consumption for operation resulted in a net clean energy output of only 455.900 Watt-Hours, which is 9.535% lower than that of the solar panel without cooling. These findings indicate that while active cooling methods like heatsinks can enhance panel efficiency, the energy consumption of the cooling mechanism itself must be carefully considered to ensure optimal net energy gains. The water cooling system, offering a balance between improved performance and minimal energy consumption, emerges as the most effective cooling strategy in maximising clean energy output.

The novelty of this study lies in its analytical approach, which not only evaluates the improvement of solar panel efficiency through active cooling systems but also integrates the assessment of net clean energy production by considering the energy consumption of the cooling mechanisms themselves. This comprehensive perspective provides a more realistic understanding of the actual benefits of cooling technologies for solar panels. The findings highlight that although the heatsink method enhances instantaneous efficiency, the water-cooling system proves to be the most effective strategy in maximizing long-term net energy gains.

Future studies may focus on several key areas of development: (1) optimizing the design of water-cooling systems through variations in flow rate, materials, and configurations to improve effectiveness with minimal energy consumption; (2) integrating cooling systems with additional renewable energy sources, such as solar-powered pumps, to achieve fully sustainable cooling solutions; (3) investigating the long-term impact of cooling on solar panel degradation and performance stability; and (4) conducting broader economic and environmental feasibility analyses, including investment value, payback period, and potential carbon emission reductions from the adoption of active cooling technologies.

REFERENCES

- [1] C. Breyer et al., "On the History and Future of 100% Renewable Energy Systems Research," IEEE Access, vol. 10, pp. 78176–78218, 2022, doi: 10.1109/ACCESS.2022.3193402.
- [2] L. M. Shaker, A. A. Al-Amiery, M. M. Hanoon, W. K. Al-Azzawi, and A. A. H. Kadhum, "Examining the influence of thermal effects on solar cells: a comprehensive review," Sustainable Energy

- [3] F. R. A. Bukit, A. Sani, I. A. Hasugian, and T. D. P. Butar-Butar, "The Affect of Solar Panel Tilt Angle with Reflector on The Output Power Using Calculation and Experimental Methods," in 2022 6th International Conference on Electrical, Telecommunication and Computer Engineering (ELTICOM), IEEE, Nov. 2022, pp. 80–84. doi: 10.1109/ELTICOM57747.2022.10037921.
- [4] M. Lemeshko, N. Stuzhenko, and I. Bessonov, "Study of Air Cooling of Solar Panels," in 2025 International Conference on Industrial Engineering, Applications and Manufacturing (ICIEAM), IEEE, May 2025, pp. 220–224. doi: 10.1109/ICIEAM65163.2025.11028444.
- [5] S. S. Koohestani and M. Santamouris, "Comprehensive review of state-of-the-art photovoltaic cooling technologies," in 2022 7th International Conference on Smart and Sustainable Technologies (SpliTech), IEEE, Jul. 2022, pp. 1–7. doi: 10.23919/SpliTech55088.2022.9854329.
- [6] P. K. Pathak, D. G. Roy, A. K. Yadav, S. Padmanaban, F. Blaabjerg, and B. Khan, "A State-of-the-Art Review on Heat Extraction Methodologies of Photovoltaic/Thermal System," IEEE Access, vol. 11, pp. 49738–49759, 2023, doi: 10.1109/ACCESS.2023.3277728.
- [7] A. Karthick, C. K. Patil, G. R. B. A, E. A. S, and S. Kannadhasan, "Passive Cooling Method for Photovoltaic Panel," in 2023 7th International Conference on Electronics, Communication and Aerospace Technology (ICECA), IEEE, Nov. 2023, pp. 13–16. doi: 10.1109/ICECA58529.2023.10395810.
- [8] Asri, Y. Away, Nasaruddin, I. Devi Sara, and A. Novandri, "Enhancement of Photovoltaic Performance With Coolant Calcium Chloride: Experimental and Predictive Modeling," IEEE Access, vol. 12, pp. 112839–112851, 2024, doi: 10.1109/ACCESS.2024.3443695.
- [9] Z. M. Alaas, "The Effects of Temperature on Photovoltaic and Different Mitigation Techniques: A Review," IEEE Access, vol. 12, pp. 180309–180327, 2024, doi: 10.1109/ACCESS.2024.3504009.
- [10] F. R. A. Bukit, M. F. Al-Khairi, K. Siddiq, R. D. F. Sat, W. A. Siagian, and J. A. Simalango, "Combination of Photovoltaic and Thermoelectric Generator (PV-TEG) Equipped with Solar Tracker Based on Fluid Mechanics Control," in 2024 8th International Conference on Electrical, Telecommunication and Computer Engineering (ELTICOM), IEEE, Nov. 2024, pp. 19–23. doi: 10.1109/ELTICOM64085.2024.10864557.
- [11] K. M. Alsayegh, A. Qaisieh, M. O. Hamdan, and B. Abu-Nabah, "Comparative Study of Frontside and Backside Water Cooling Systems for Photovoltaic Panels," in 2024 IEEE Sustainable Power and Energy Conference (iSPEC), IEEE, Nov. 2024, pp. 1–5. doi: 10.1109/iSPEC59716.2024.10892369.
- [12] M. Mohammadi, R. Z. Davarani, and F. Z. DolatAbad, "Economic Evaluation of Applying Fan Cooling System for Photovoltaic Modules in Tropical Regions of Iran," in 2022 12th Smart Grid Conference (SGC), IEEE, Dec. 2022, pp. 1–6. doi: 10.1109/SGC58052.2022.9998961.
- [13] S. K. Marudai pillai, B. Karuppudayar Ramaraj, R. K. Kottala, and M. Lakshmanan, "Experimental study on thermal management and performance improvement of solar PV panel cooling using form stable phase change material," Energy Sources, Part A: Recovery, Utilization, and Environmental Effects, vol. 45, no. 1, pp. 160–177, Apr. 2023, doi: 10.1080/15567036.2020.1806409.
- [14] M. R. Goma, M. Ahmed, and H. Rezk, "Temperature distribution modeling of PV and cooling water PV/T collectors through thin and thick cooling cross-fined channel box," Energy Reports, vol. 8, pp. 1144–1153, Apr. 2022, doi: 10.1016/j.egy.2021.11.061.
- [15] V. H. Bui, V. A. Truong, V. L. Nguyen, and T. L. Duong, "Estimating the potential maximum power point based on the calculation of short-circuit current and open-circuit voltage," IET Power Electronics, vol. 17, no. 3, pp. 402–421, Feb. 2024, doi: 10.1049/pel2.12651.
- [16] S. Shahria, Md. H. Ullah, M. Mashud, A. H. Mokther, E. Hoq, and Md. M. Rahman, "Effect of Temperature and Solar Panel Position on Solar PV System Performance: A Review," Energy and Thermofluids Engineering, vol. 2, pp. 39–48, May 2023, doi: 10.38208/ete.v2.729.
- [17] M. E. B. Ghribi, L. Garcia-Gutierrez, Z. E. T. Ternifi, Z. Zheng, G. Bachir, and M. Aillerie, "Tracking the maximum power point of solar panels through direct estimation of optimum voltage with temperature," Clean Energy, vol. 8, no. 4, pp. 135–146, Aug. 2024, doi: 10.1093/ce/zkae044.